

High-pressure two-line system with hydraulically controlled change-over valve

The pressure line and the relief line connect the central lubrication pump with the change-over valve.

From there two main lines lead to the lubricant metering devices which are connected via branch lines into the system.

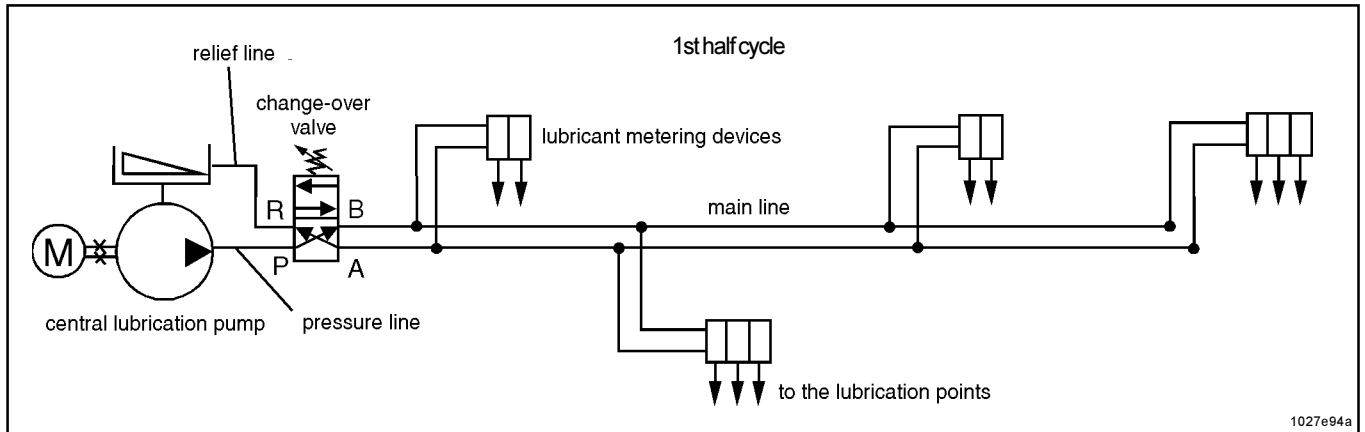

After the central lubrication pump has been switched on, lubricant is delivered to the main line „B“ via pressure line and change-over valve. The main line „A“ is connected with the pump reservoir via change-over valve and relief line. The pump unit continues to deliver lubricant and the pressure in the main line „B“ continues to rise until the flow resistance, working pressure of the metering devices as well as the entry resistance at the lubrication points are overcome. Only then will the control and measuring pistons of the metering devices be operated and a measured amount of lubricant is delivered to the lubrication points.

The lubrication system is hydraulically closed which causes pressure to rise until the working pressure preset at the change-over valve is reached. As soon as this pressure is reached the process of changing over is initiated via the spring-loaded valve piston of the change-over valve with the result that the pressure line is connected with the so far decompressed main line „A“. At the same time the so far compressed main line „B“ is connected with the relief line. This main line is now able to relief in the direction of the pump reservoir. This process is indicated by the indicator pin of the change-over valve. At the same time the attached limit switch is actuated and the pump motor is switched off and the pause time begins. This is the completion of one half lubrication cycle.

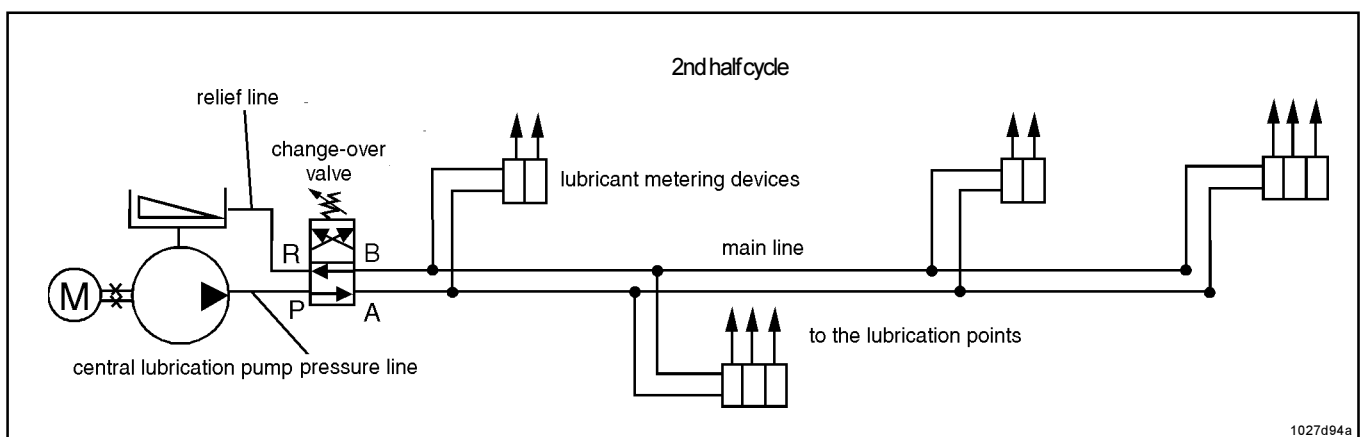

After the pause time has expired the pump motor is again energized and, due to the pressure rise in the main line „A“ that is now connected with the pressure line, the pistons of the metering devices are again operative thus allowing the second half of the connected lubrication points to be supplied with the scheduled amount of lubricant.

The process of pressure rising, changing over, pump motor switching off and pause time initiating - as described above - is repeated. After that one lubrication cycle is completed and all connected lubrication points have been fed with the preset amount of lubricant.

Subject to modifications