

## High - pressure two - line system with electrically controlled change over valve

The pressure line and the relief line connect the central lubrication pump with the change-over valve. From there two main lines lead to the lubricant metering devices which are connected via branch lines into the system.

The end-of-line pressure switches are installed at the end of longest main line, in any case upstream of the last metering device.

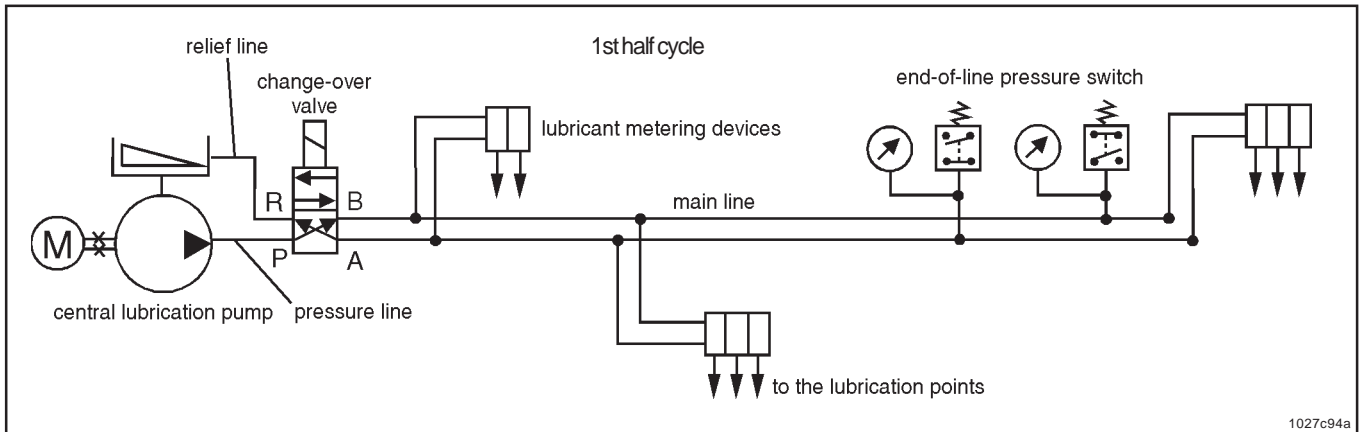

After the central lubrication pump has been switched on, lubricant is delivered to the main line „B“ via pressure line and change-over valve. The main line „A“ is connected with the pump reservoir via change-over valve and relief line. The pump unit continues to deliver lubricant and the pressure in the main line „B“ continues to rise until the flow resistance, working pressure of the metering devices as well as the entry resistance at the lubrication points are overcome. Only then will the control and measuring pistons of the metering devices be operated and a measured amount of lubricant is delivered to the lubrication points.

The lubrication system is hydraulically closed which causes the pressure to rise until the working pressure preset at the end-of-line pressure switch is reached. The end-of-line pressure switch signals an electric pulse to the change-over valve which initiates the process of changing over with the result that the pressure line is connected with the so far decompressed main line „A“. At the same time the so far compressed main line „B“ is connected with the relief line. This main line is now able to relieve in the direction of the pump reservoir. The pump motor is switched off and the pause time begins. This is the completion of one half lubrication cycle.

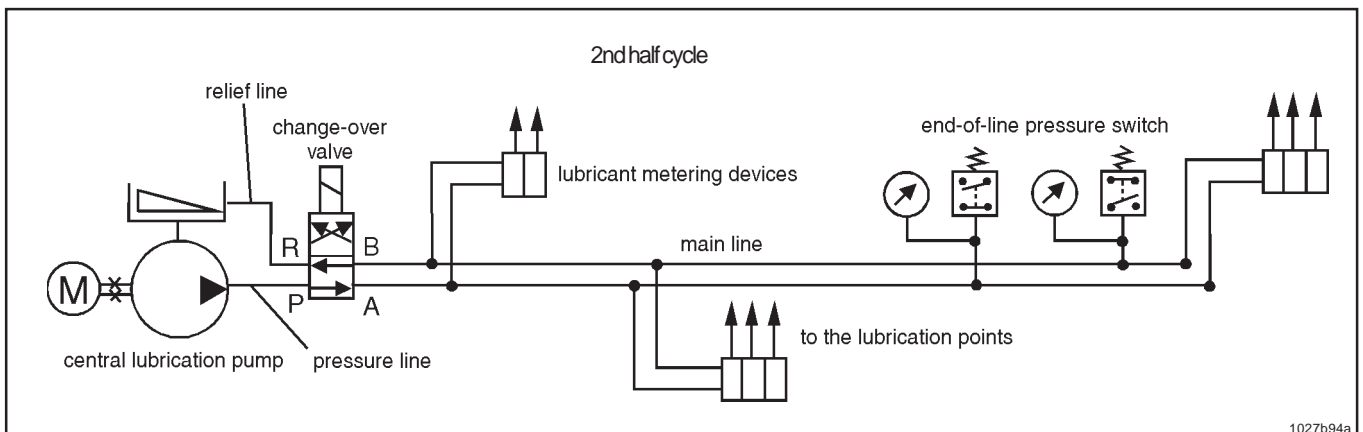

Subject to modifications After the pause time has expired the pump motor is again energized and, due to the pressure rise in the main line „A“ that is now connected with the pressure line, the pistons of the metering devices are again operative thus allowing the second half of the connected lubrication points to be supplied with the scheduled amount of lubricant.

The process of pressure rising, changing over, pump motor switching off and pause time initiating - as described above - is repeated. After that one lubrication cycle is completed and all connected lubrication points have been fed with the preset amount of lubricant.